

ADVANTAGE SERIES

PRECISION MEASUREMENT & CONTROL SOLUTIONS FOR PIPE AND TUBE



Measurement & Control

- Medical
- Irrigation
- Automotive
- Industrial
- Heat Shrink

BETA LaserMike Products

Meeting the Challenges of Today's Pipe & Tube Industry

Plastic pipe and tube manufacturers face challenges as diverse as the markets and customers they serve. Producers of IVs, catheters or other **medical tubes** face strict regulations from government organizations and customers that hold them liable for absolute product quality and safety.

Automotive tube manufacturers have high demands for tubing that holds tight tolerances, along with thorough documentation to prove

quality claims. **Heat-shrink tube** manufacturers must extrude consistent wall thickness before taking the tubes to expansion lines, in order to ensure proper thermal shrink ratios.

Manufacturers of **irrigation, industrial** or any of a wide variety of **pipe and tube products** for consumer and commercial applications must constantly strive to find new ways to increase production efficiencies and reduce manufacturing costs in order

to improve profit margins in a competitive environment – while ensuring quality control and safety.

Nordson Measurement & Control Solutions offers ultra-accurate, ultra-efficient measurement and control solutions so you can take charge of every aspect of your pipe or tube production operations: from diameter and ovality, wall thickness and concentricity, fault detection, length and speed, and more.

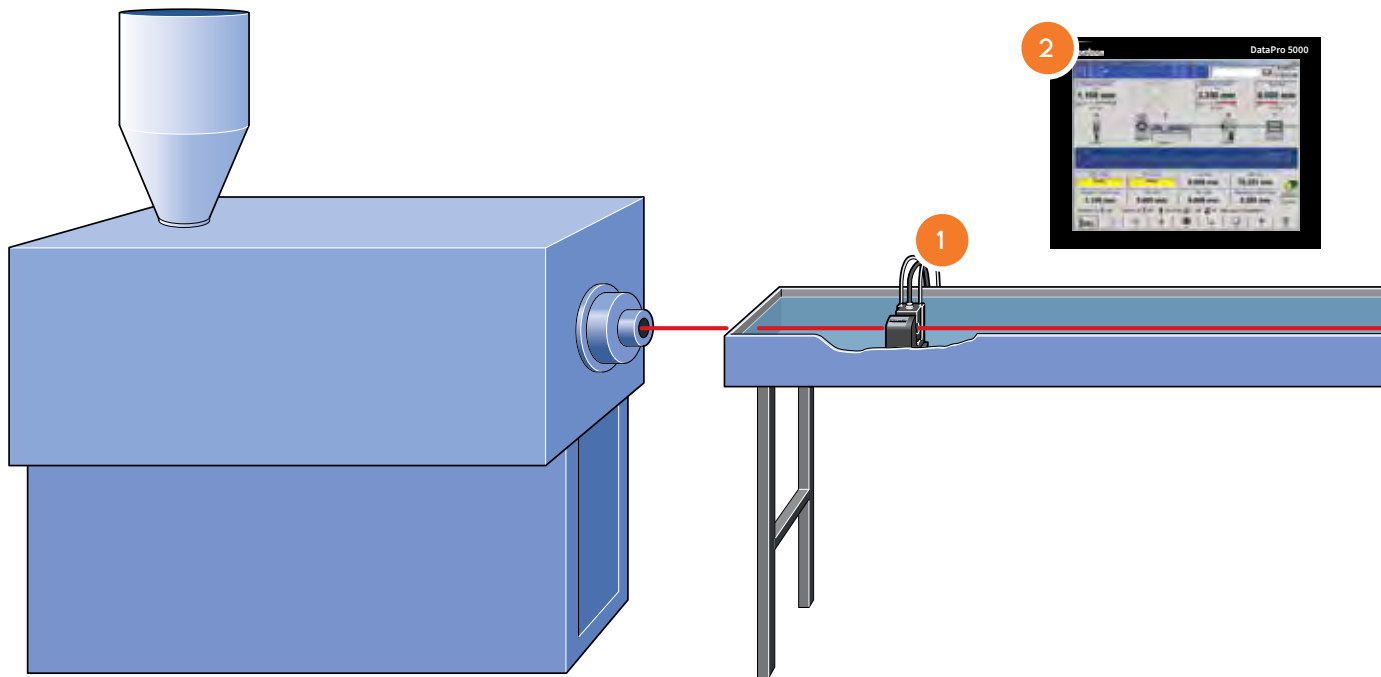

A Legacy of Leadership

Based on over 50 years of leadership, Nordson products offer end-to-end solutions for your pipe and tube production needs. The industry-leading capabilities enable you to automate setups, improve production control and better manage process data.

Benefit from:

- ▶ Reduced start-up times
- ▶ Enhanced uptime reliability
- ▶ Increased product quality
- ▶ Minimized waste and rework
- ▶ Lower manufacturing costs

And with Nordson's global network of service and support organizations, and myNDC cloud-based customer service portal, professional assistance is never far away.

Precision Measurement & Control Systems

1 TrueWall
Wall & Concentricity

2 DataPro
Process Control

3 AccuScan
Diameter & Ovality

4 LN Detector
Lump & Neckdown
Detection

5 LaserSpeed Pro
Non-Contact
Length & Speed

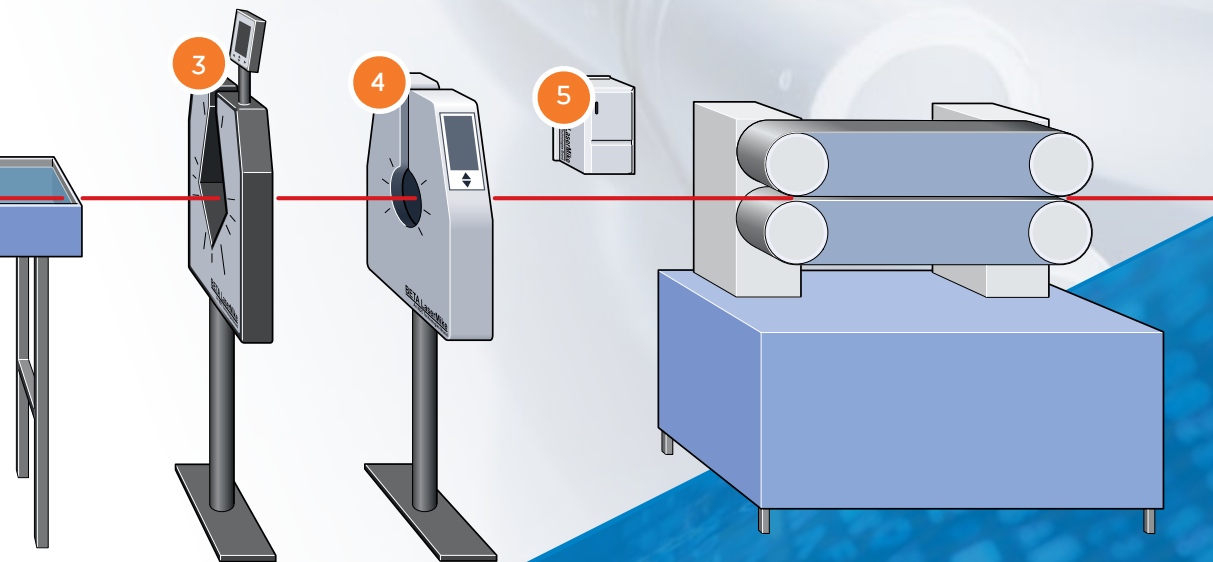

Industry
4.0

As the world continues to “go digital,” the demand for top-quality pipe and tube products – and the challenges of their production – are bound to increase. The proven performance of Nordson products will help you meet these challenges so you can lead, rather than follow, in this highly competitive industry.

Realize the Benefits of Implementing a Nordson Measurement System

Reduce Start-Up Time with Die Centering

The start-up of a pipe and tube extrusion line is often the cause of scrapped material and the most significant loss of production time. Without an on-line gauging and control system that shows the true cross-sectional profile of the product's concentricity, the operator's only tool to quickly center the die is his or her own skill and experience, and perhaps a bit of luck. The Nordson DataPro system works in conjunction with the TrueWall wall & concentricity gauge to take the inefficiency out of the extrusion startup.



Die Centering

Start-Up Problem

The result of a die-centering adjustment is unknown until the pipe or tube reaches the end of the line.

Multiple iterations of die centering adjustments are often required increasing start-up time. The number of iterations of die centering adjustments is very dependent on operator experience.

DataPro and TrueWall Solution

Provides real-time, on-line cross-sectional view of pipe and tube concentricity, which greatly reduces the delay between the time of a die centering adjustment and when the operator sees the result of that adjustment.

Reduces the dependence of start-up time on the experience of the operator by allowing more iterations of die centering adjustments to take place in the same amount of time.

Decrease Material Usage and Give Away with Closed-Loop Control

Most pipe and tube extrusion operators run the line at sizes that are well above the minimum specifications in order to ensure they do not create scrap product. This ensures that the extrusion line is operating with maximum uptime, but it also creates a scenario where all finished product includes a high amount of material "give away."

The DataPro system helps you eliminate such losses. Its advanced closed-loop control capabilities provide up to four control loops whose data can be used for automatically making the setting adjustments needed to maintain production accuracy. Automatically control process-critical line equipment such as extruders, pullers and other process devices. You're able to manufacture more high-quality pipe and tube – and account for every meter – to optimize output and profitability.



Closed-Loop Control

Improve and Document Product Quality with SPC

While DataPro's die-centering and closed-loop control capabilities enable you to *optimize* production quality, the system's SPC data analysis features help you *maintain and improve* it. During each production run, DataPro synthesizes a continuous stream of process measurement data and displays this information on eight SPC channels so you can –

- Spot relevant trends for better control of production operations
- Identify and head off issues that could degrade performance before they become a problem
- Maintain the repeatability needed to consistently manufacture superior-quality products

And with its powerful reporting features, DataPro lets you generate the SPC documents needed to assure customers and ISO auditors that you can deliver on your quality claims.



SPC Data Analysis and Reporting

Improve Data Management with Real-Time Communication

In manufacturing, communications and quality go hand in hand. The DataPro system includes a wide range of tracking and reporting functions that give you a real-time window into production operations. Use these powerful communications tools to improve your data management and analysis capabilities for more effective process control – and greater product quality.

- Generate real-time trend charts to track data sets by time, length, or data point intervals
- Produce quality reports manually or automatically at any point during the production run
- Capture and log process data by time period, product length or line speed
- Set alarms that provide error alerts plus log the errors for later review
- Integrate DataPro at the network location best suited to support data management efficiency



Real-Time Trend Charts

System Solutions for Your Pipe & Tube Production Application

Solutions for Tube Extrusion Industry

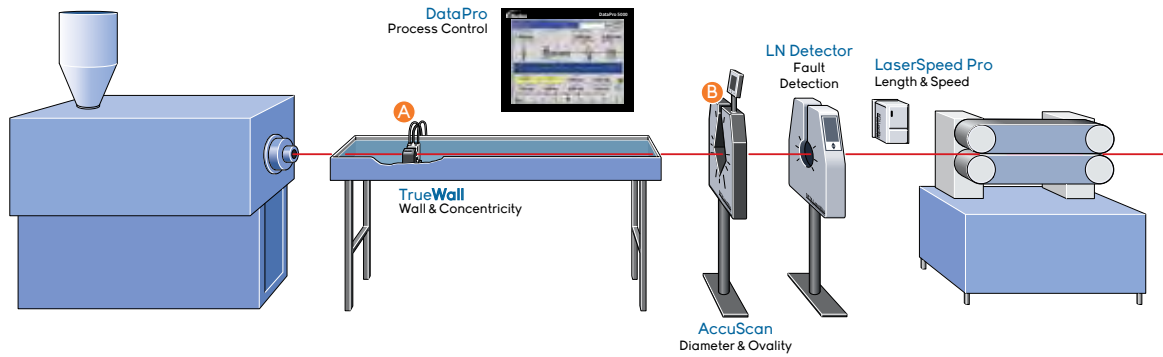

Solution*	Gauge Inputs		Config. #
	AccuScan	TrueWall	
Diameter; Ovality	B		-01
Wall; Concentricity		A	-20
Wall; Concentricity; Diameter; Ovality	B	A	-22

*LN Series lump & neck detector and LaserSpeed length and speed gauge can be added to any configuration.

Solutions for Pipe Extrusion Industry

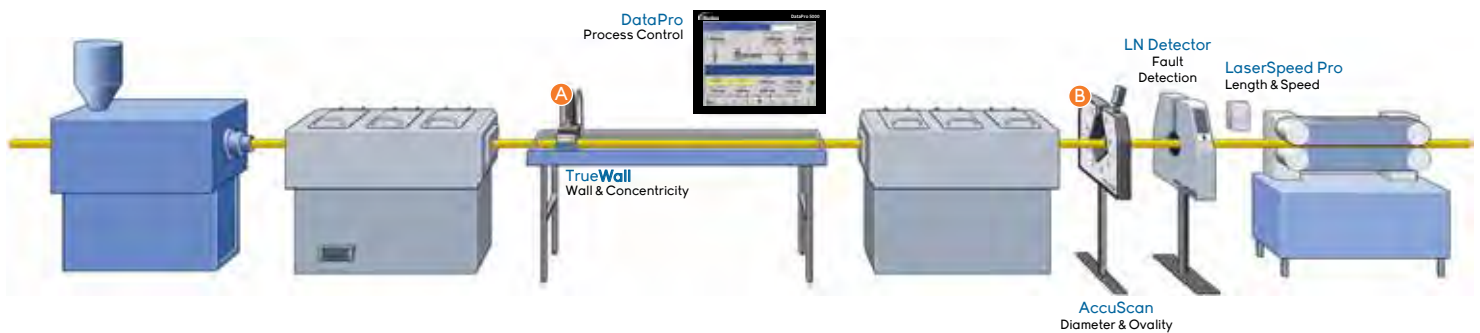

Solution*	Gauge Inputs			Config. #
	AccuScan	TrueWall	TrueWall Diameter	
Diameter; Ovality	B			-01
Diameter; Ovality; Shrinkage Correction	B			-02
Diameter; Ovality; ID/Core; Calculated Wall Thickness	B			-10
Diameter; Ovality; ID/Core; Shrinkage Correction; Calculated Wall Thickness	B			-12
Wall; Concentricity		A		-20
Wall; Concentricity; Diameter; Ovality		A	A	-21
Wall; Concentricity; Diameter; Ovality	B	A		-22
Wall; Concentricity; Diameter; Ovality; Shrinkage Compensation	B	A	A	-23

*LN Series lump & neck detector and LaserSpeed length and speed gauge can be added to any configuration.

Diameter and Ovality Measurement

The **BETA LaserMike** AccuScan Series is the premier diameter and ovality gauge of choice for manufacturers looking to produce higher quality products in less time and with less waste. AccuScan gauges perform ultra-fast, precise and reliable diameter and ovality measurements in an intelligent head to instantly detect product changes and effectively communicate these measurements to a host system or controller. Available in single-, dual- and four-axis configurations, AccuScan make sure your pipe and tube products meet the tightest design and quality specifications.

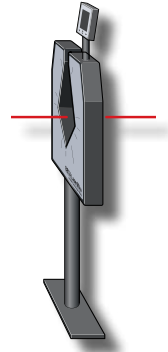

AccuScan Advantages

- AS6000 Series gauges provide the most comprehensive measurement coverage and highest ovality accuracy over three-axis gauges
- AS6000/5000 gauges perform high-speed measurements at 2400 scans/sec/axis, offering the highest single-scan accuracy in the industry
- Single-scan flaw detection option permits the early, accurate and dependable detection of product lumps and necks to eliminate costly product waste
- Glass logic option enables you to measure transparent/translucent products
- Increase up-time and reduce maintenance costs with built-in lens air purge and IP65 (NEMA 4) construction



	AS 6000 Series	AS 5000 Series	AS Pro
Scanning Axes	Four-Axis	Dual-Axis	Single-Axis
OD Range	0.1 to 50 mm (0.004 to 2.00 in.)	0.1 to 80 mm (0.004 to 3.15 in.)	0.13 to 100 mm (0.005 to 3.94 in.)
Gate Size	AS6012: 16 mm (0.63 in.) AS6050: 60 mm (2.36 in.)	16 to 108 mm (0.63 to 4.25 in.)	52 - 106 mm (2.05 - 4.17 in.)
Accuracy	±0.005 mm to ±0.001 mm (±0.000020 in. ¹ to ±0.00004 mm ²)	±0.0005 mm to ±0.002 mm (±0.000020 in. ¹ to ±0.00008 mm ²)	±0.001 - ±0.002 mm (±0.000040 - ±0.000080 in.) ¹
Communications	RS-232, EtherNet/IP, Ethernet TCP/IP, DeviceNet, Profinet, Profibus, CANOpen and other protocols		

¹ ±0.02% of product size.

² 0.01% of product size for 80 mm gauges.

Process Control and Data Management

Process control and data management systems, when coupled with Nordson gauges and a versatile set of I/O capabilities, enable you to produce superior quality products by providing all the information and control capability you need to keep your production process running smoothly. Nordson systems aid, and improve, the manufacturing process at every step, from the start-up period to the production period to the final quality checks.



Features

Display	48.3 cm (19 in) Touch screen
Gauge support	AccuScan 5000/6000 TrueWall LN3000 LaserSpeed Pro
Max gauges	Not Limited
Applications	Inner/Outer Diameter Fault Detection Wall & Concentricity Length & Speed Lump & Neck
Cross-section display	Yes (multi-layer possible)
Control loops	2
Auto setpoint control	Yes
SPC	8 graphical channels
Trend charts	5 channels
Printed reports	Yes (custom)
Data logging	20 channels
Serial ports	RS-232 & USB
Ethernet port	Yes (10/100 Base T)
Alarming	Yes
Product recipes	Yes (unlimited)
Security	10 levels (custom)
I/O	Digital, analog, relay contacts, serial, USB/Network printer, Ethernet, VGA
Interfaces with PLC	Yes

Real-Time Monitoring of Process & Product Quality Data



Home Page displays cross-sectional view of pipe and tube concentricity, and enables you to precisely monitor product dimensions, reel length and line speed to reduce start-up time and scrap for quality production. Easily customize the Main Menu to the way you work.

Display up to 12 parameter tiles at one time in place of trend data on the home page.

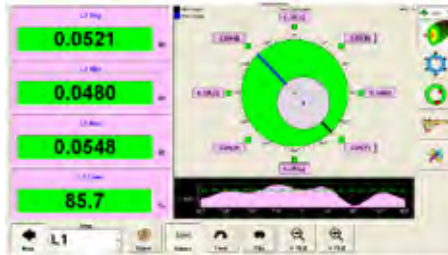

Closed-Loop Control provides up to 2 control loops. Use control outputs to control line equipment such as Puller, Extruder, Air Pressure, Take-Up and other devices.

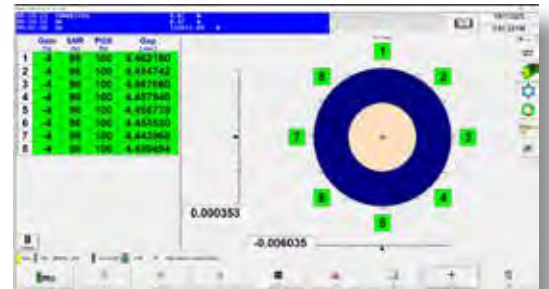

Detailed Status Pages give you a real-time view of measurement data, overall performance and status to streamline setup and easily perform diagnostics. For example, you can view product centering information, monitor the signal-to-noise ratio of each ultrasonic transducer.



Real-Time Trend Charts allow you to simply select, track and record the desired data set. Program and display up to eight tiles and/or up to four trends of dimensional data.



SPC Data Analysis feature collects and displays process data on 8 individual channels. View real-time SPC charts, display real-time SPC statistics and generate SPC reports to improve your production process and ensure repeatable product quality while advancing the effectiveness of your quality documentation.



Configuration Editor lets you easily visualize the current extrusion line configuration. Add or modify product and process parameters. Set up and adjust hardware, production line layout and I/O settings without any special technical knowledge.

Fault Detection Systems

The LN3000 Series accurately detects short-term faults (lumps and neckdowns) in the diameter of pipes and tubes before they become costly production issues. These three-axis scanning systems combine comprehensive surface monitoring, high-speed circuitry and solid-state infrared lighting to detect product surface changes as small as 0.02 mm (±0.0008 in.) – at line speeds up to 3000 m/min (9840 ft./min)! You get ultra-accurate, real-time fault reporting so you can come as close as possible to fault-free pipe and tube production.

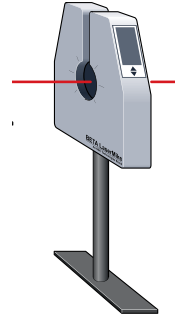

LN3000 Series Advantages

- Tracks and reports all critical surface fault data – height, length, number, and location – to improve quality control
- Enhances its own performance with built-in diagnostics for assessing scanning signal strength, optics cleanliness and other key aspects of system operations
- Comes with many different communications options to simplify connecting with PLCs and a host PC
- Accepts a range of inputs, including length encoder, line start/stop, clear faults, and reel change, for better production control

2-Axis vs 3-Axis Measurement

The three-axis LN Series detector provides a higher degree of coverage around the product's circumference compared to two-axis gauges. These gauges precisely detect the smallest of flaws at higher production line speeds.

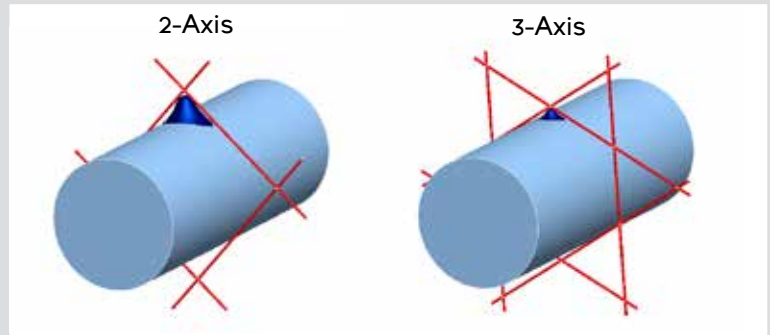

	LN3015	LN3050
Product Diameter	0.02 to 15 mm (0.0008 to 0.6 in.)	0.04 to 40 mm (0.0016 to 1.57 in.)
Gate Size	18 mm (0.71 in.)	48 mm (1.89 in.)
Minimum Detectable Flaw Height	0.02 mm (0.0008 in.)	0.05 mm (0.0020 in.)
Accuracy	Greater of either ±0.011 mm (±0.0004 in.) or ±3% max flaw height	Greater of either ±0.018 mm (±0.0007 in.) or ±3% max flaw height
Communications	RS-232, telnet, DeviceNet, Ethernet, EtherNet/IP, Profinet, Profibus (optional)	

Non-Contact Length and Speed Measurement



The **BETA LaserMike** LaserSpeed Pro gauge is the industry's leading non-contact length and speed gauge, offering numerous advantages over mechanical contact encoders and competing optical measurement technologies. Among the first non-contact measuring systems on the market over 30 years ago, LaserSpeed Pro combines advanced optics with an ultra-stable laser diode system to deliver **better than ±0.03% accuracy with ±0.02% repeatability for measurements on the most difficult surfaces**. Over 10,000 gauges installed worldwide.



Flexible Connectivity



The optional DP700 Plus display shows LaserSpeed length, velocity, quality factor, and gauge status, and lets you configure gauge and process settings.

LaserSpeed Pro Advantages

- Non-contact measurement ensures no marking or damage of the product
- Measures forward, reverse and down to true zero speed on all product types regardless of shape, color and texture
- Versatile Ethernet connectivity supports Industry 4.0 standards
- LaserTrak Software suite provides complete digital control over setup and operation
- Fast baud rates, multiple host connections and real-time clock for syncing gauges with networked devices for unsurpassed communications performance
- Advanced, ultra-stable laser diode, backed by 3-year warranty, doubles lifetime of conventional diodes and provides longest service life in the industry!
- **2-Year product warranty** on all other LaserSpeed Pro product components



Safety Enclosure

	4500 Series	8500 Series	9500 Series
Standoff Distance	100 mm (4.0 in.) to 600 mm (24 in.)	300 mm (12.0 in.) to 1000 mm (39.4 in.)	300 mm (12.0 in.) to 1000 mm (39.4 in.)
Speed Range	0.2 to 8000 m/min (0.7 to 26,200 ft./min)	0.4 to 12000 m/min (1.3 to 39,400 ft./min)	0..±4000 to 0..±12000 m/min (0..±13100 to 0..±39,400 ft./min)
Measurement Depth of Field	15 mm (0.6 in.) to 50 mm (2.0 in.)	35 mm (1.4 in.) to 100 mm (4.0 in.)	35 mm (1.4 in.) to 100 mm (4.0 in.)
Fieldbus Connectivity	ModBus TCP, Ethernet/IP, Profinet IO, Profibus DP		
Outputs	Full RS-422 compatible quadrature or voltage scaleable pulse outputs to the existing control system and RS-422 and RS-232 serial outputs. Pulses per unit (e.g., m/min.) are configurable. Analog output.		
Options	Air Wipe, Quick Change Window, Air Purge, Environmental Housings, Adjustable Mounting Bracket, Safety Stand, DP700 Touch-Screen Display		

Wall and Concentricity Measurement

The **BETA LaserMike TrueWall** system is the industry's leading ultrasonic wall thickness and concentricity measurement system. Its high performance and outstanding productivity features make it the preferred solution for the measurement of pipe and tube. This allows manufacturers to increase production efficiencies and reduce material costs by better controlling product wall thickness and concentricity.

Depending on the application, TrueWall gauges are available to cover various product diameter and wall thickness sizes in both fixed and adjustable transducer distance styles. Each supports multiple transducers and is capable of measuring several layers.

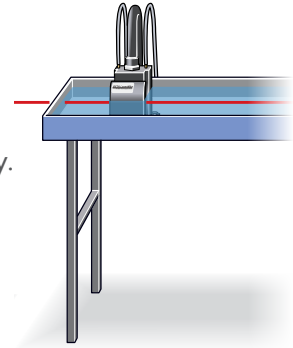

TrueWall Advantages

- Powerful and unique TrueWall digital signal processor with patented "Snap Technology" provides fully automatic setup and calibration, making operation quick and simple (see below)
- Versatile Ethernet connectivity, multiple host connections, extended baud rates, built-in web server and more
- Find short-term wall variations with high-speed tolerance checking option
- Other options include diameter and ovality measurement, trough height stand and small trough for mounting outside existing cooling troughs
- 2-year product warranty on all TrueWall product components



TrueWall Patented Snap Technology

All ultrasonic measurement systems require setup of the ultrasonic waveform. But while other systems require extensive user involvement during this process, TrueWall's **patented Snap Technology**, with its Auto-Search, Auto-Setup, and Auto-Tracking functions, makes waveform setup instantaneous and completely automatic.

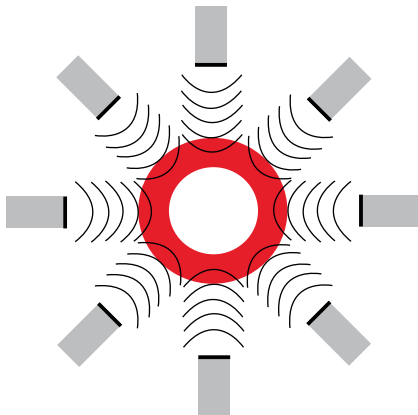

Auto-Search: TrueWall finds the echoes and sets a "window" around them.

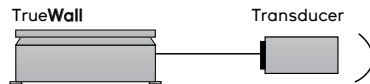

Auto-Setup: TrueWall interprets the ultrasonic waveform and identifies the proper echoes.

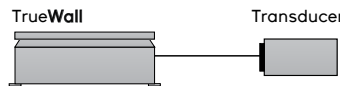

Auto-Tracking: TrueWall locks onto the proper echoes and tracks them as the product moves.

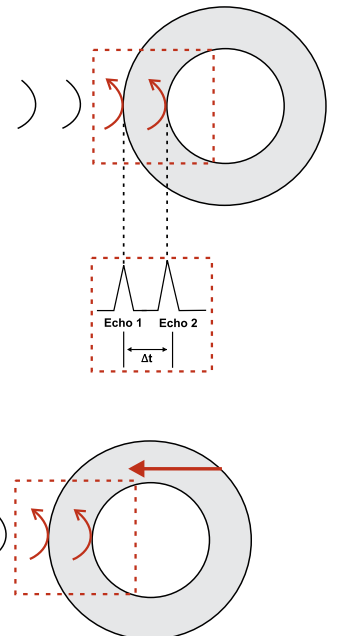
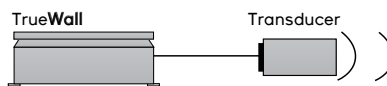

NEW!
Configuration/Operation
via **Embedded
Webserver**

NEW! Embedded Webserver

TrueWall's new webserver provides setup and configuration of the system, displays centering, wall thickness, eccentricity, and diameter. This provides all the functionality a line operator needs for quick setup and monitoring of the manufacturing process. An additional benefit is it comes without the need for extra, costly hardware. Integration of external OD measurements, line speed, and other digital inputs/outputs create powerful capabilities.

The result is the ability to set and control the quality of product, minimize cost, and integrate the system easily with production instrumentation and equipment. Echo waveforms also can be monitored, and settings optimized for successful measurements on the most difficult to measure products. Recipe, settings configuration, and internal diagnostics capability ensure commissioning and startup of equipment is quick and easy. The WebServer eliminates the need for a PC-based control application or separate controller, enhancing TrueWall's ease of use and lowering its total cost of ownership.

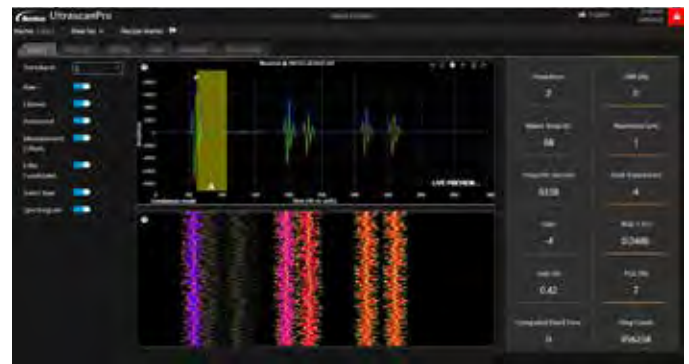

For optimum resolution, the recommended monitor sizes are: 20 inch (1600 x 900 display) in landscape mode or 19 inch (1280 x 1024 display).

Specifications

	Model 1012	Model 1025	Model 1040
OD Range	0.25 to 12 mm (0.01 to 0.5 in.)	2.5 to 25 mm (0.1 to 1.0 in)	4.0–40 mm (0.16–1.57 in.)
Minimum Wall Thickness	Without Thin Wall: 10 MHz: 0.254 mm (0.010 in.) 20 MHz: 0.127 mm (0.005 in.) With Thin Wall: 20 MHz: 0.025 mm (0.001 in)	Without Thin Wall: 10 MHz: 0.254 mm (0.010 in) 20 MHz: 0.127 mm (0.005 in) With Thin Wall: 20 MHz: 0.025 mm (0.001 in)	10 MHz: 0.254 mm (0.010 in)
Transducers	4,8	4,8	4,8

	Model 1063
OD Range	7.5–63 mm (0.30)
Minimum Wall Thickness	5 MHz: 0.508 mm (0.020 in) 10 MHz: 0.254 mm (0.010 in.)
Transducers	4, 8

Communications (all models):

- | | |
|------------------|------------------|
| Ethernet: | Fieldbus: |
| - ModBus TCP | - Profibus, |
| - EtherNet/IP | - DeviceNet |
| - Profinet IO | |



Another Option for Off-Line Part Measurement

The AccuNet QC Pro is the latest, economical off-line diameter and ovality measurement solution that provides total quality control of your part samples. Perfect for use in a lab or at a production floor QC station, AccuNet QC Pro enables you to effectively track, manage and analyze critical product data. An optional high-resolution digital microscope with zoom optics helps you precisely position the product to capture the desired diameter and ovality measurements with a maximum degree of accuracy.

Use the optional footswitch to easily start and stop measurements as you guide the product through the gauge. You control what you want to measure by simply configuring a part recipe using a variety of system options.



AccuNet QC Pro Advantages

- Take a snap-shot or continuous scan of your part feature
- Capture instantaneous “go/no go” measurements
- Set up Nominal and either Bilateral or Symmetric tolerances
- Acquire absolute Min/Max or Average on any feature
- Include up to 15 features per recipe
- View trend graphs – diameter and/or ovality
- Perform data logging
- Obtain test results summary with “go/no go” highlighted dimensions
- Use unlimited recipes
- Get live camera feed of laser positioning on part (optional)



Quick, Easy Setup



Track Diameter & Ovality Data

	AccuNet QC Pro
Computer	IBM PC or compatible, 2.4 GHz processor
Operating System	Microsoft® Windows 7, Windows 8, Windows 10, Windows 11, or Vista
RAM	2 GB
Hard Drive	80 GB
Input Options	USB: using single- or multiple-port USB to DB9 serial converter Ethernet: using 5-port Ethernet switch
Optional	Camera: high-resolution digital color with zoom optics Footswitch
Gauges	AccuScan Pro Single-axis gauge AccuScan 5000 Series: Two-axis gauge AccuScan 6000 Series: Four-axis gauge

Note: Turnkey system available with PC, monitor, footswitch and ultra-bright display.

Off-Line ID/OD/Wall Measurement System

BenchMike Pro is the next evolution of the industry's leading off-line ID/OD/Wall Thickness measurement system with thousands of gauges installed worldwide. The foremost manufacturers rely on BenchMike Pro's fast measurements, $\pm 0.9 \mu\text{m}$ accuracy and $\pm 0.25 \mu\text{m}$ repeatability to help them deliver the superior-quality products their customers demand.

For example: for precision ID/OD/Wall measurements, simply place a pipe or tube sample on the ID/OD/Wall fixture and BenchMike Pro will calculate all the dimensions. This fixture can also automatically rotate a sample to a pre-defined number of positions for measurements at multiple points around the product. This rotation also allows for the calculation of concentricity and ovality of the product. A variety of modular fixtures are available for any gauging need to properly hold workpieces.



Data Display

BenchMike Advantages

- Uses auto-compensation to maintain accuracy throughout the measurement range and to adjust for thermal expansion
- Employs tolerance checking for quickly alerting operators to out-of-tolerance conditions
- Improves efficiency with a library of stored recipes that operators can use for quickly switching products
- Accepts a range of part-holding fixtures for consistent presentation of the cable samples to be measured
- Comes with many different communications options for more flexible connection to centralized production networks, PCs, data devices and CUPS-supported USB printers
- Includes a large touchscreen display to improve measurement data viewing



Pop-Up Menu



Library (Part) Selection

OD Measurement



Use our V-Block fixture to make precision OD measurements on pipe or tube samples.

ID/OD/Wall Measurements on Small Tubing



User our Force Gauge fixture to make precision ID/OD/Wall Thickness measurements on thin-wall small diameter tubing, such as medical tubing. Place the tube sample on the fixture, apply the desired force and BenchMike Pro calculates all the dimensions.

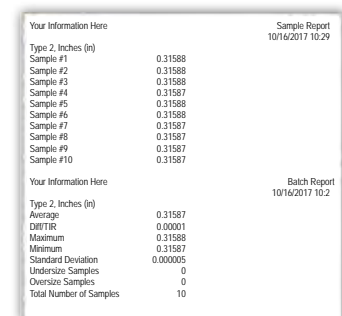

Printed Reports

	Model 2025	Model 2050
Measurement Range	0.100 to 25.4 mm (0.004 to 1.0 in.)	0.254 to 50 mm (0.10 to 2.0 in.)
Accuracy	$\pm 0.9 \text{ mm}$ ($\pm 0.000036 \text{ in.}$)	$\pm 1.5 \text{ mm}$ ($\pm 0.000060 \text{ in.}$)
Communications	Serial (DB9 and USB), USB printer port, Ethernet, Digital I/O, Fixture port, Scan output BNC	

Optimizing Your Investment with World-Class Service and Support

Nordson's technical expertise comes from deep experience supporting thousands of products at the world's leading manufacturers. Our portfolio of support offerings leverages this expertise to assist you through the service lifecycle. We offer a complete range of cost-effective support solutions including commissioning, training, technical support and service agreements. Customers rely on our 24-7 availability via myNDC – the industry's most progressive service cloud portal. Whether it's configuring new equipment, training your technical staff or solving a technical problem, you can count on our experienced team to help maintain the health and performance of your Nordson product.

Visit myNDC service cloud at ndc.custhelp.com.



For questions or support go to: <https://ndc.custhelp.com/>

In line with its policy of continuous improvement, Nordson reserves the right to revise or replace its products or services without prior notice. The information contained in this document may not represent the latest specification and is for indicative purposes only.

Document #: C&T-BROC-SENS-Nordson Pipe Tube Market-EN-2026MAR04
Date of Issue: March 2026
© Nordson Corp. 2026

Nordson Measurement & Control is represented in over 60 countries worldwide. www.nordson.com