

Series 5
IN 5 plus IMPAC Pyrometer



MANUAL

Confidential Information

The material contained herein consists of information that is the property of LumaSense Technologies, an Advanced Energy Company, and intended solely for use by the purchaser of the equipment described in this manual.

All specifications are subject to change without notice. Changes are made periodically to the information in this publication, and these changes will be incorporated in new editions.

LumaSense Technologies prohibits the duplication of any portion of this manual or the use thereof for any purpose other than the operation or maintenance of the equipment described in this manual, without the express written permission of LumaSense Technologies or Advanced Energy Industries, Inc.

Any unauthorized use of this manual or its contents is strictly prohibited.

Copyright

© 2019 LumaSense Technologies, Inc. All Rights Reserved. LumaSense Technologies, Inc., a subsidiary of Advanced Energy Industries, Inc.

Trademarks

IMPAC is a trademark of LumaSense Technologies.

All other trademarks are trademarks, registered trademarks, and/or service marks of their respective holders.

Service Centers

LumaSense Technologies, Inc.

North America

Sales & Service

Santa Clara, CA, USA

Ph: +1 800 631 0176

Ph: +1 408 727 1600

Fax: +1 408 727 1677

LumaSense Technologies GmbH

Other Than North America

Sales & Support

Frankfurt, Germany

Ph: +49 (0) 69 97373 0

Fax: +49 (0) 69 97373 167

Global and Regional Centers

Our Headquarters

LumaSense Technologies, Inc.

Santa Clara, CA, USA

Ph: +1 800 631 0176

Fax: +1 408 727 1677

Americas, Australia, & Other Asia

LumaSense Technologies, Inc.

Santa Clara, CA, USA

Ph: +1 800 631 0176

Fax: +1 408 727 1677

Europe, Middle East, Africa

LumaSense Technologies GmbH

Frankfurt, Germany

Ph: +49 (0) 69 97373 0

Fax: +49 (0) 69 97373 167

France

LumaSense Technologies Sarl

Erstein, France

Ph: +33 3 8898 9801

Fax: +33 3 8898 9732

India

LumaSense Technologies, India

Mumbai, India

Ph: + 91 22 67419203

Fax: + 91 22 67419201

China

LumaSense Technologies, China

Shanghai, China

Ph: +86 133 1182 7766

Ph: +86 21 5899 7915

E-mail info@lumasenseinc.com
 support@lumasenseinc.com
 eusupport@lumasenseinc.com

Website <http://www.lumasenseinc.com>

Part No 3 869 017

Revision F

January 2019

Contents

1	General	5
1.1	Information about the user manual	5
1.1.1	Legend	5
1.1.2	Terminology.....	5
1.2	Safety	5
1.2.1	Laser targeting light	6
1.2.2	Electrical connection.....	6
1.3	Limit of liability and warranty	6
1.4	Unpacking the Instrument	7
1.5	Service Request, Repair, or Support	7
1.6	Shipments to LumaSense for Repair	7
1.7	Transport, packaging, storage	8
1.8	Disposal / decommissioning	8
2	Introduction	9
2.1	Appropriate use	9
2.2	Scope of delivery	9
2.3	Technical data	9
2.4	Dimensions	12
2.5	Physical User Interface	12
2.6	Accessories (Optional)	13
3	Controls and Installation	15
3.1	Electrical Installation	15
3.1.1	Pin assignment for the connector on the back of the pyrometer.....	15
3.1.2	Connecting the pyrometer to a PC.....	16
3.1.3	Connecting to RS232 interface.....	16
3.1.4	Connecting to RS485 interface.....	16
3.1.5	Connection of additional analyzing devices	17
3.2	Sighting	17
3.2.1	Alignment with laser targeting light	17
3.2.2	Thermal alignment	18
3.3	Optics	18
4	Instrument Settings	21
4.1	Instrument settings	21
4.1.1	Switches at the instrument.....	21
4.1.2	Instrument switches.....	21
4.2	Factory settings	22

5	Settings / Parameter Descriptions	23
5.1	Online- / offline mode (ONL/OFFL).....	23
5.2	Emissivity (EMI).....	23
5.3	Exposure time (t_{90}).....	24
5.4	Analog output 0/4 to 20 mA.....	25
5.5	Maximum / minimum value storage.....	25
5.6	Subrange.....	26
5.7	Baud rate.....	26
5.8	Address.....	26
5.9	Ambient temperature compensation.....	27
5.10	Wait time t_w	27
5.11	Internal temperature of the pyrometer	27
5.12	Avoiding reading errors caused by faulty assembly.....	28
6	Software InfraWin	29
6.1	Connecting the pyrometer to a PC	29
6.2	Installation	29
6.3	Program start.....	29
7	Maintenance	31
7.1	Safety.....	31
7.2	Service.....	31
8	Troubleshooting.....	33
9	Data format UPP	35
10	Reference numbers	39
10.1	Reference numbers instrument	39
10.2	Reference numbers accessories	39
	Index.....	41

1 General

1.1 Information about the user manual

Congratulations on choosing the high quality and highly efficient IMPAC pyrometer.

This manual provides important information about the instrument and can be used as a work of reference for installing, operating, and maintaining your IMPAC pyrometer. It is important that you carefully read the information contained in this manual and follow all safety procedures before you install or operate the instrument.

To avoid handling errors, keep this manual in a location where it will be readily accessible.

1.1.1 Legend



Note: The note symbol indicates tips and useful information in this manual. All notes should be read to effectively operate the instrument.



Attention: This sign indicates special information which is necessary for a correct temperature measurement.



Warnings and Cautions: The general warnings and cautions symbol signifies the potential for bodily harm or damage to equipment.



Security note laser beam

Indicates to the danger of a built-in laser targeting light.

MB

Shortcut for Temperature range (in German: **Messbereich**).

1.1.2 Terminology

The terminology used in this manual corresponds to the VDI- / VDE-directives 3511, Part 4.

1.2 Safety

This manual provides important information on safely installing and operating the IMPAC pyrometer. Several sections of this manual provide safety warnings to avert danger. These safety warnings are specified with a warning symbol. You must read and understand the contents of this manual before operating the instrument even if you have used similar instruments or have already been trained by the manufacturer.

It is also important to continually pay attention to all labels and markings on the instrument and to keep the labels and markings in a permanent readable condition.



Warning: The pyrometer is only to be used as described in this manual. It is recommended that you only use accessories provided by the manufacturer.

In addition, signs and markings on the device are to be observed and maintained in legible condition.

1.2.1 Laser targeting light

For easy alignment to the measuring object the pyrometers can be equipped with a laser targeting light. This is a visible red light with a wavelength between 630 and 680 nm and a maximum power of 1 mW. The laser is classified as product of laser class II.



Warning: To reduce the risk of injury to the eyes, do not look directly into the targeting laser and do not point the targeting laser into anyone's eyes. The instrument is equipped with a class II laser that emits radiation.



- Never look directly into the laser beam. The beam and spot can be watched safely from side.
- Make sure that the beam will not be reflected into eyes of people by mirrors or shiny surfaces.

1.2.2 Electrical connection

Follow common safety regulations for mains voltage (e.g. 230 or 115 V AC) connecting additional devices operating with this mains voltage (e.g. transformers). Touching mains voltage can be mortal. A non-expert connection and mounting can cause serious health or material damages.

Only qualified specialists are allowed to connect such devices to the mains voltage.

1.3 Limit of liability and warranty

All general information and notes for handling, maintenance, and cleaning of this instrument are offered according to the best of our knowledge and experience.

LumaSense Technologies is not liable for any damages that arise from the use of any examples or processes mentioned in this manual or in case the content of this document should be incomplete or incorrect. LumaSense Technologies reserves the right to revise this document and to make changes from time to time in the content hereof without obligation to notify any person or persons of such revisions or changes.

All instruments from LumaSense Technologies have a regionally effective warranty period. Please check our website at <http://info.lumasenseinc.com/warranty> for up-to-date warranty information. This warranty covers manufacturing defects and faults, which arise during operation, only if they are the result of defects caused by LumaSense Technologies.

The *Windows compatible software* was thoroughly tested on a wide range of Windows operating systems and in several world languages. Nevertheless, there is always a possibility that a Windows or PC configuration or some other unforeseen condition exists that would cause the software not to run smoothly. The manufacturer assumes no responsibility or liability and will not guarantee the performance of the software. Liability regarding any direct or indirect damage caused by this software is excluded.

The warranty is VOID if the instrument is disassembled, tampered with, altered, or otherwise damaged without prior written consent from LumaSense Technologies; or if considered by LumaSense Technologies to be abused or used in abnormal conditions. There are no user-serviceable components in the instrument.

1.4 Unpacking the Instrument

Thoroughly inspect the instrument upon delivery to purchaser. Check all materials in the container against the enclosed packing list. LumaSense Technologies cannot be responsible for shortages against the packing list unless a claim is immediately filed with the carrier. The customer must complete final claim and negotiations with the carrier.

Save all packing materials, including the carrier's identification codes, until you have inspected the pyrometer and find that there is no obvious or hidden damage. Before shipment, the pyrometer was examined and has been tested. If you note any damage or suspect damage, immediately contact the carrier and LumaSense Technologies, Inc.

1.5 Service Request, Repair, or Support

Contact LumaSense Technologies Technical Support in case of a malfunction or service request. Provide clearly stated details of the problem as well as the instrument model number and serial number. Upon receipt of this information, Technical Support will attempt to locate the fault and, if possible, solve the problem over the telephone.

If Technical Support concludes that the instrument must be returned to LumaSense Technologies for repair, they will issue a Return Material Authorization (RMA) number.

Return the instrument upon receipt of the RMA number, transportation prepaid. Clearly indicate the assigned RMA number on the shipping package exterior. Refer to Section **1.6, Shipments to LumaSense for Repair**, for shipping instructions.

Technical Support can be contacted by telephone or email:

Santa Clara, California

- Telephone: +1 408 727 1600 or +1 800 631 0176
- Email: support@lumasenseinc.com

Frankfurt, Germany

- Telephone: +49 (0) 69 97373 0
- Email: eusupport@lumasenseinc.com

Erstein, France

- Telephone +33 (0)3 88 98 98 01
- Email: eusupport@lumasenseinc.com

1.6 Shipments to LumaSense for Repair

All RMA shipments of LumaSense Technologies instruments are to be prepaid and insured by way of United Parcel Service (UPS) or preferred choice. For overseas customers, ship units air-freight, priority one.

The instrument must be shipped in the original packing container or its equivalent. LumaSense Technologies is not responsible for freight damage to instruments that are improperly packed.

Contact us to obtain an RMA number (if Technical Support has not already assigned one). Clearly indicate the assigned RMA number on the shipping package exterior.

Send RMA Shipments to your nearest technical service center:

Customers in **North America** should send RMA Shipments to:

Santa Clara, California

LumaSense Technologies, Inc.
3301 Leonard Court
Santa Clara, CA 95054 USA
Telephone: +1 408 727 1600
+1 800 631 0176

Email: support@lumasenseinc.com

All other customers should send RMA Shipments to:

Frankfurt, Germany

LumaSense Technologies GmbH
Kleyerstr. 90
60326 Frankfurt
Germany
Telephone: +49 (0)69-97373 0

Email: eusupport@lumasenseinc.com

1.7 Transport, packaging, storage

With faulty shipping, the instrument can be damaged or destroyed. To transport or store the instrument, please use the original box or a box padded with sufficient shock-absorbing material. For storage in humid areas or shipment overseas, the device should be placed in welded foil (ideally along with silica gel) to protect it from humidity.

The pyrometer is designed for a storage temperature of -20 to 70 °C with non-condensing conditions. Storing the instrument out of these conditions can cause damage or result in malfunction of the pyrometer.

1.8 Disposal / decommissioning

Inoperable IMPAC pyrometers must be disposed of in compliance with local regulations for electro or electronic material.

2 Introduction

2.1 Appropriate use

IN 5 plus: The IMPAC pyrometer IN 5 plus is a stationary infrared thermometer for non-contact temperature measurement of non-metallic surfaces or painted, coated or anodized metals with a temperature range from -32 to 900 °C.

IN 5-L plus: as IN 5 plus, with small spot size.

IN 5-H plus: as IN 5 plus, with shorter exposure time.

For optimal match of the instrument to the application the pyrometers are equipped ex works with the desired optics (for every instrument 3 different optics are available).

All settings which are necessary for a correct temperature measurement can be adjusted at the pyrometer itself (emissivity, exposure time, analog output (0 or 4 to 20 mA) and online- / offline-mode). Additionally, further pyrometer settings can be made via serial interface RS232 or RS485 (specified when ordering) and a PC and the standard software InfraWin. Also, temperature indication, analyzing of the measurement and data logging can be done with this software.

2.2 Scope of delivery

Instrument with selected optic, works certificate, PC measurement and evaluation software InfraWin.



Note: The connection cable is not included with the instrument and must be ordered separately (see section **10, Reference numbers**).

2.3 Technical data

Temperature Ranges:	IN 5 plus & IN 5-H plus: -32 ... 900 °C (MB 9) IN 5-L plus: 0 ... 900 °C (MB 9)
IR Detector:	Thermopile
Sub Range:	User adjustable (minimum span is 51 °C)
Data Handling:	Digital
Spectral Range:	8 ... 14 µm
Power Supply:	24 V DC (18 ... 30 V); nominal, ripple must be less than 0.5 V
Power Consumption:	Max. 70 mA
Load:	Max. 500 Ω @ 24 V (max. 200 Ω @ 18 V)
Response Time t_{90} :	IN 5 plus: 0.08 s IN 5-H plus: 0.01 s IN 5-L plus: 0.18 s } Adjustable in the pyrometer: 0.5 s; 1 s; 2 s; 5 s Adjustable via interface: 0.5 s; 1 s; 2 s; 5 s; 10 s; 30 s
Analog Output:	0 ... 20 mA or 4 ... 20 mA (linear), adjustable

Maximum / minimum value storage:	Built-in single and double storage. Clearing with clear time t_{clear} (0.1 s; 0.25 s; 0.5 s; 1 s; 5 s; 25 s), external contact or via interface or also automatically with each new item to be measured
Interface:	RS232 or RS485 (addressable, half duplex), baud rate 1.2 up to 19.2 kBd, resolution 0.1 °C
Isolation:	Power supply, analog outputs and digital interfaces are electrically isolated from each other
Parameters:	Adjustable on the pyrometer: Emissivity, Exposure time, analog output to 0 ... 20 mA, online / offline switch Via interface / PC adjustable and readable: (online mode) Emissivity, exposure time, 0 or 4 ... 20 mA analog output, sub temperature range, max./min value storage with different clear times or automatic or external clearing mode, address, baud rate, internal temperature, temperature display in °C or °F, activation of ambient temperature compensation
Emissivity ε :	0.2 ... 1 adjustable
Measurement Uncertainty: Dependent on object temperature T and ambient temperature T_{amb} ($\varepsilon = 1, t_{90} = 1$ s)	IN 5 plus: T = -32 ... 0 °C: 1.5 °C ($T_{amb} = 15 \dots 30$ °C); 2 °C ($T_{amb} = 0 \dots 15$ or $30 \dots 63$ °C) T = 0 ... 300 °C: 0.6% of reading in °C or 1 °C ($T_{amb} = 15 \dots 30$ °C) ¹ 1% of reading in °C or 1.5 °C ($T_{amb} = 0 \dots 15$ or $30 \dots 63$ °C) ¹ T = 300 ... 900 °C: 1% of reading in °C ($T_{amb} = 15 \dots 30$ °C) 1.3 % of reading in °C ($T_{amb} = 0 \dots 15$ or $30 \dots 63$ °C) IN 5-H plus: T = -32 ... 0 °C: 3 °C ($T_{amb} = 15 \dots 30$ °C); 4 °C ($T_{amb} = 0 \dots 15$ or $30 \dots 63$ °C) T = 0 ... 300 °C: 0.6% of reading in °C or 1.5 °C ($T_{amb} = 15 \dots 30$ °C) ¹ 1% of reading in °C or 2 °C ($T_{amb} = 0 \dots 15$ or $30 \dots 63$ °C) ¹ T = 300 ... 900 °C: 1% of reading in °C ($T_{amb} = 15 \dots 30$ °C) 1.3 % of reading in °C ($T_{amb} = 0 \dots 15$ or $30 \dots 63$ °C) IN 5-L plus: T = 0 ... 300 °C: 0.6% of reading in °C or 2 °C ($T_{amb} = 15 \dots 30$ °C) ² 1% of reading in °C or 3 °C ($T_{amb} = 0 \dots 15$ or $30 \dots 63$ °C) ² T = 300 ... 900 °C: 1% of reading in °C ($T_{amb} = 15 \dots 30$ °C) 1.5 % of reading in °C ($T_{amb} = 0 \dots 15$ or $30 \dots 63$ °C)
Repeatability: ($\varepsilon = 1, t_{90} = 1$ s)	0.3% of reading in °C or 0.6 °C ³

Noise Equivalent Temperature Difference (NETD): ($\epsilon = 1, T_{amb} = 23\text{ °C}$)	<p>IN 5 plus: @ $t_{90} = 80\text{ ms}$: 0.2 °C (@ 23 °C measuring temperature) @ $t_{90} = 1\text{ s}$: 0.05 °C (@ 23 °C measuring temperature)</p> <p>IN 5-H plus: @ $t_{90} = 10\text{ ms}$: 0.7 °C (@ 23 °C measuring temperature) @ $t_{90} = 1\text{ ms}$: 0.1 °C (@ 23 °C measuring temperature)</p> <p>IN 5-L plus: @ $t_{90} = 180\text{ ms}$: 0.3 °C (@ 23 °C measuring temperature) @ $t_{90} = 180\text{ ms}$: 0.2 °C (@ 200 °C measuring temperature) @ $t_{90} = 1\text{ s}$: 0.15 °C (@ 23 °C measuring temperature) @ $t_{90} = 1\text{ s}$: 0.1 °C (@ 200 °C measuring temperature)</p>
Protection Class:	IP65 (DIN 40050)
Ambient Temperature:	0 ... 63 °C
Storage Temperature:	-20 ... 70 °C
Rel. Humidity:	Non-condensing conditions
Weight:	Approx. 410 g
Housing:	Stainless steel
Operating Position:	Any
Sighting:	Laser targeting light (max. power level < 1 mW, $\lambda = 630 \dots 680\text{ nm}$, CDRH class II) 
Optics:	IN 5 plus & IN 5-H plus: Zinc-Sulfide (ZnS) IN 5-L plus: Zinc-Selenide (ZnSe)
CE-label:	According to EU directives about electromagnetic immunity

¹Whichever value is greater. The instrument must be at a const. amb. temp. for min. 15 min. and has to be connected to the power supply.

²Whichever value is greater. The instrument must be at a const. amb. temp. for min. 30 min. and has to be connected to the power supply.

³Whichever value is greater. The instrument must be at a constant ambient temperature for a minimum of 15 minutes (IN 5 plus or IN 5-H plus) or 30 minutes (IN 5-L plus).

Note: The determination of the technical data of this pyrometer is carried out in accordance with VDI/VDE directive IEC TS 62942-2, "Determination of the technical data for radiation thermometers".



The calibration / adjustment of the instruments was carried out in accordance with VDI/VDE directive "Temperature measurement in industry, Radiation thermometry, Calibration of radiation thermometers", VDI/VDE 3511, Part 4.4.

For additional details on this directive, see <http://info.lumasenseinc.com/calibration> or order the directive from "Beuth Verlag GmbH" in D-10772 Berlin, Germany.

2.4 Dimensions

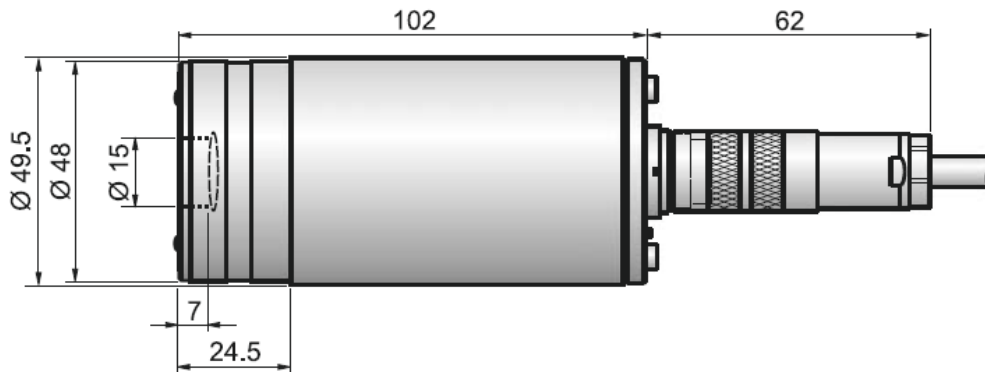

2.5 Physical User Interface

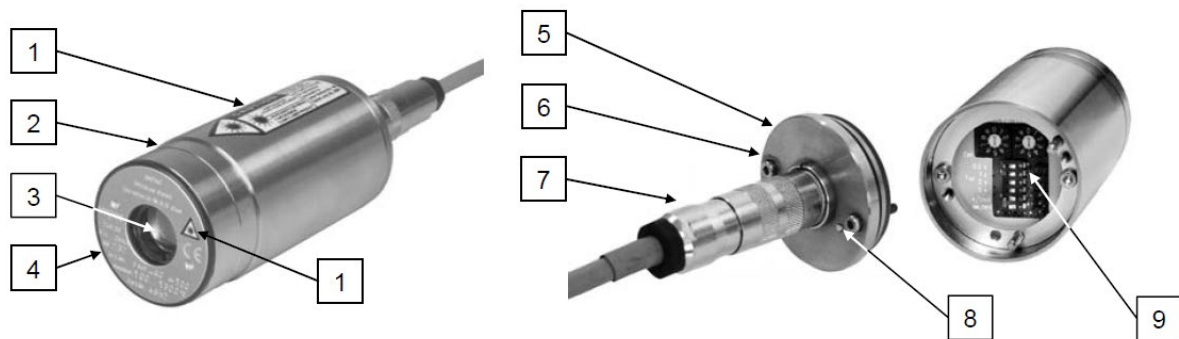

- | | |
|--|--|
| 1 Laser warning label (only instruments with laser targeting light) | 6 Fixing screws for rear panel |
| 2 Stainless steel housing | 7 Electrical connector |
| 3 Optics | 8 Laser targeting light button |
| 4 Type label | 9 Setting keys at the pyrometer |
| 5 Housing rear panel | |

2.6 Accessories (Optional)

Numerous accessories guarantee easy installation of the pyrometer. The following overview shows a selection of suitable accessories. You can find the entire accessory program with all reference numbers in Chapter **10, Reference numbers**.

Mounting:

For easy mounting and aligning the pyrometer to the measured object an adjustable *mounting angle* is available.



Mounting angle

Cooling:

The completely covered water cooling jacket made from stainless steel protects the pyrometer if exposed to a hot environment. It is designed for ambient temperatures up to 180 °C.



Water cooling jacket with integrated air purge

Miscellaneous:

The air purge protects the lens from contamination with dust and moisture. It has to be supplied with dry and oil free pressurized air and generates an air stream shaped like a cone.

The pyrometer can be easily fixed on a vacuum chamber with the KF 16 vacuum support with sighting window.



Air purge units



Vacuum support

Displays:

For temperature indication of the pyrometer IMPAC offers several digital displays.



Digital display
DA 6000

To ensure consistent document formatting, this page was intentionally left blank.

3 Controls and Installation

3.1 Electrical Installation

The series 5 pyrometers are powered by 24 V DC nominal (possible range: 18 to 30 V DC, ripple must be less than 0.5 V). When connecting the device to the power supply ensure correct polarity. The instrument has no warm-up time, with connection to the power the instrument operates immediately, but still needs 15 or 30 min (depending on the type, see technical data) to achieve its full accuracy. To switch off the instrument, interrupt the power supply or unplug the electrical connector.

To meet the electromagnetic requirements (EMV), a shielded connecting cable must be used. The shield of the connecting cable has to be connected only on the pyrometer's side. On side of the power supply (switch board) the shield must be open to avoid ground loops.

LumaSense offers connecting cables, they are not part of standard scope of delivery. The connecting cable has wires for power supply, interface, analog output, external laser switch and external clear of maximum value storage via contact (see section **10, Reference numbers**) and 12 pin connector. The cable includes a short RS232 adapter cable with a 9 pin SUB-D connector for direct PC communication. This adapter is not used in combination with RS485 interface.

3.1.1 Pin assignment for the connector on the back of the pyrometer

Pin	Color	Indication
K	white	+ 24 V power supply (18 to 30 V)
A	brown	0 V power supply
L	black	+ I _{output} . analog output
B	yellow	- I _{output} . analog output
H	gray	external switch for targeting light (bridge to K)
J	pink	external clearing of maximum value storage (bridge to K) ¹
G	red	DGND (ground for interface)
F	black	RxD (RS232) or B1 (RS485)
C	violet	TxD (RS232) or A1 (RS485)
D	gray/pink	B2 (RS485) (bridge to F)
E	red/blue	A2 (RS485) (bridge to C)
M	orange	screen only for cable extension, don't connect at the switchboard

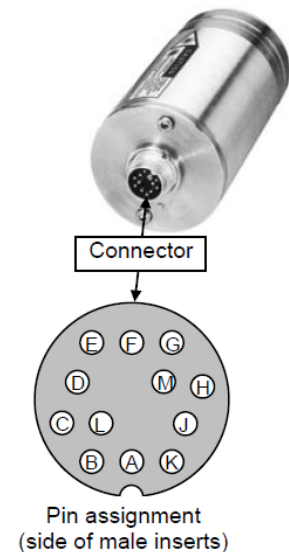

¹For setting of clear time to "extern" (see **5.5 Maximum / minimum value storage**)

3.1.2 Connecting the pyrometer to a PC

The pyrometers are equipped with a serial interface RS232 or RS485 (switchable at the pyrometer). Standard on a PC is the RS232 interface. At this interface one pyrometer can be connected if the interface is set to RS232. Only short distances can be transmitted with RS232 and electromagnetic interferences can affect the transmission.

With RS485 the transmission is to a large extent free of problems, long transmission distances can be realized, and several pyrometers can be connected in a bus system. If RS485 is not available at the PC, it can be realized with an external converter which converts the RS485 in RS232 for a standard connection to a PC.

When using a converter RS485↔RS232 take care, that the converter is fast enough to receive the pyrometer's answer to an instruction of the master. Most of the commonly used converters are too slow for fast measuring equipment. So, it is recommended to use the LumaSense converter I-7520 (order no. 3 852 430).

3.1.3 Connecting to RS232 interface

The transmission rate (in baud) of the serial interface is dependent on the length of the cable. Values between 1200 and 19200 Bd may be set.

The baud rate has to be reduced by 50% when the transmission distance is doubled (see also **5.7 Baud rate**)

Typical cable length for RS232 at 19200 Bd is 7 m.

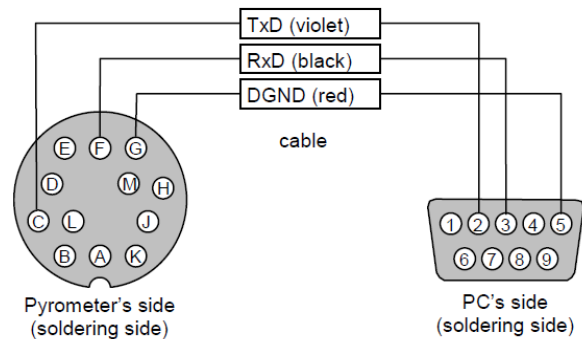

3.1.4 Connecting to RS485 interface

Half-duplex mode:

A1 and A2 as well as B1 and B2 are bridged in the 12-pin round connector of the connecting cable, to prevent reflections due to long stubs. It also safeguards against the interruption of the RS485 Bus system should a connecting plug be pulled out. The master labels mark the connections on the RS485 converter. The transmission rate of the serial interface in Baud (Bd) is dependent on the length of the cable. Values between 1200 and 19200 Bd may be set.

The baud rate is reduced by 50% when the transmission distance is doubled (see **5.7 Baud rate**). Typical cable length for 19200 Bd is 2 km.

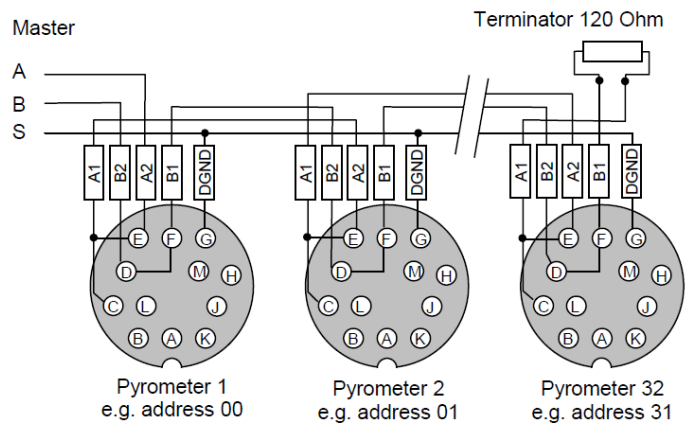

3.1.5 Connection of additional analyzing devices

Additional analyzing instruments, for example a LED digital display instrument only needs to be connected to a power supply and the analog outputs from the pyrometer. Another Instruments like a controller or printer can be connected to the display in series as shown above (total load of resistance max. 500 Ohm).

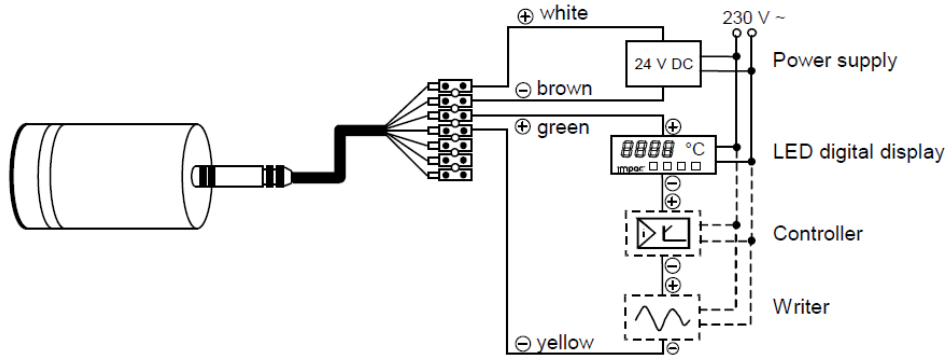

3.2 Sighting

For exact measurement of the object temperature the pyrometer must be aligned correctly onto the object. For this alignment the pyrometers are equipped with a laser targeting light. This laser enables the simple and accurate alignment even onto small objects.

3.2.1 Alignment with laser targeting light

The laser point marks the center of the spot, not the exact size. The correct focusing distance with the smallest spot size is achieved when the laser point has its smallest size. The laser does not affect the temperature measurement.

The laser targeting light can be activated either by pressing the button at the rear side of the housing, by using an external contact (see **3.1.1 Pin assignment** for the connector on the back of the pyrometer), or with the InfraWin software. The laser can be switched off by pressing the button again or it is automatically switched off after approx. two minutes.



Warning: To reduce the risk of injury to the eyes, do not look directly into the targeting laser and do not point the targeting laser into anyone's eyes. The instrument is equipped with a class II laser that emits radiation.



Note: The laser warning signs on the pyrometer should be easily viewable at all times, even after it has been installed.



Note: To prevent the damage of the laser, the pilot light switches off automatically if the internal temperature of the device exceeds approx. 50 °C (it can switched-on again, if the internal temperature is lower than 50 °C).

3.2.2 Thermal alignment

When measuring a hot object in front of a cooler background, it usually suffices to align the pyrometer to achieve the highest temperature reading.

3.3 Optics

The pyrometers are equipped ex works with one of the following optics. These lenses are focusing to certain distances. In these distances each lens achieves its smallest spot size. The spot size will enlarge in any other distance (shorter or longer). Please notice that the measuring object must be as least as big as the spot size.

The name of the optics (e.g. optics 300) shows the measuring distance in mm (e.g. 300 mm) in which it has the smallest spot size (IN 5 plus, e.g. 6 mm).

The following drawings show the size of the spots in mm in dependence of the measuring distance. Values between the mentioned data can be calculated by interpolation. The spot size for measuring distance 0 is the aperture diameter of the optics.

IN 5 plus, IN 5-H plus

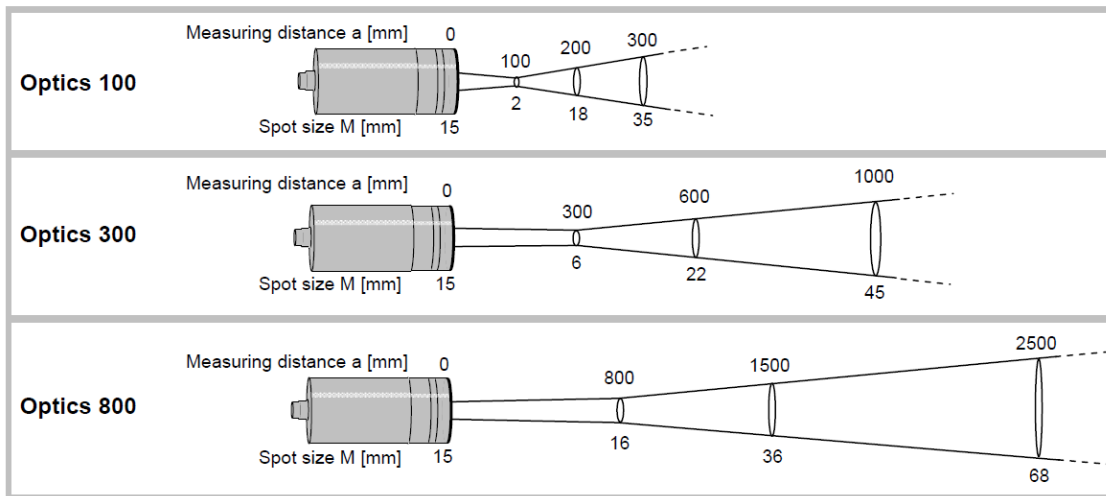

IN 5-L plus

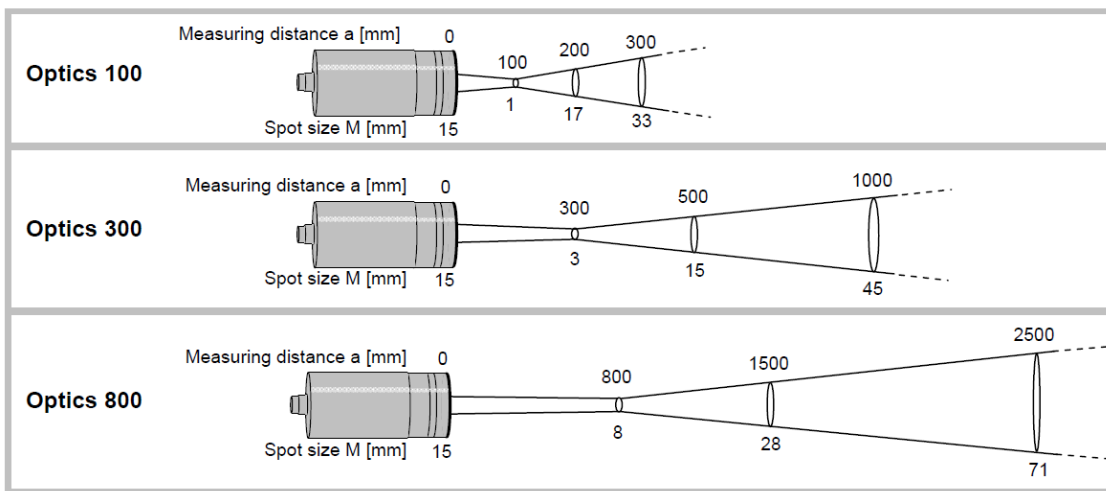

Note: Please note that the optical profiles show nominal dimensions. The spot size diameter or the focal distance may be slightly different due to lens tolerances.



Note: The *InfraWin* program includes a Spot size calculator that roughly estimates the unknown values. The values represented here are for reference purposes.

Spot sizes for intermediate distances, that are not shown on the optical profiles, may be calculated using the following formula:

$$M_2 = \frac{a_2}{a}(M - D) + D$$

$$M_1 = \frac{a_1}{a}(M + D) - D$$

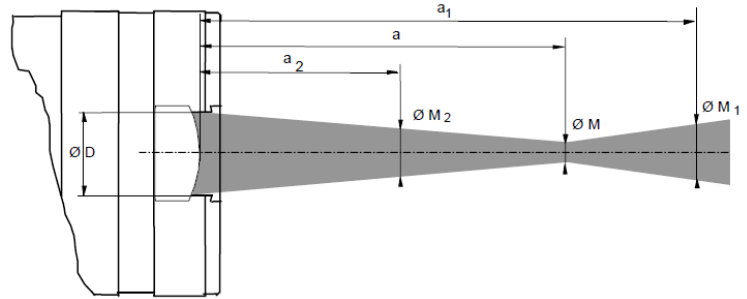

To ensure consistent document formatting, this page was intentionally left blank.

4 Instrument Settings

4.1 Instrument settings

Before using the pyrometer, some basic settings should be taken. The basic settings can be done at the pyrometer itself, some further settings can be done via interface and software InfraWin.

Settings at the instrument: The basic settings are emissivity, exposure time, analog output. These settings can be adjusted at the pyrometer only in offline mode (see **5.1 Online- / offline mode (ONL/OFFL)**).

Settings via serial interface: The pyrometer is equipped with a serial interface RS232 or RS485 (corresponding to the ordered version) which can be used for connection to a PC. With the standard software InfraWin (or a self-written communication software) the following settings can be done (the pyrometer must be in online mode (ONL) to use these functions, see **5.1**): emissivity, exposure time, analog output, maximum value storage, minimum value storage, reading of the instrument's internal temperature, setting of an address for bus control with RS485 interface, setting of the baud rate, function for compensating of the off-set of the ambient temperature). Additionally, InfraWin enables the temperature display and analysis.

4.1.1 Switches at the instrument

The controls / switches are located under the rear cover of the pyrometer and can be accessed by removing the rear cover in the following way:

1. Disconnect the electrical connection.
2. Unscrew the rear screws with a 2.5 mm allen screw.
3. Take the cover off, making sure it remains straight (without bending or twisting it).

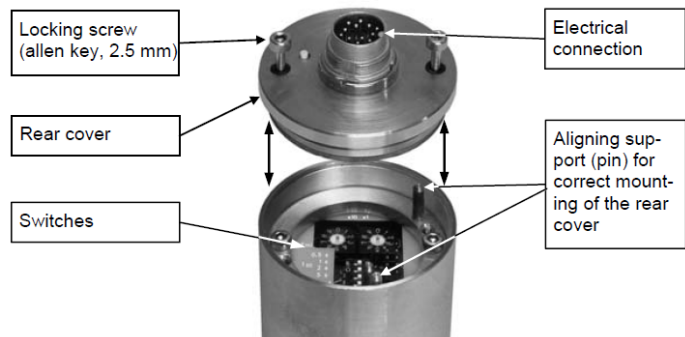

Note: Please make sure that the pyrometer is not contaminated while open.

Assembling: When reassembling the cover, insert it carefully into the guide pins and then fasten it with the screws. The connector cable can now be plugged in.

4.1.2 Instrument switches



For a description of the setting see chapter **5, Parameters / Settings**.

4.2 Factory settings

Instrument settings:

Emissivity (Emi) = 100%

Exposure time (t_{90}) = 0.08 s

Analog output(4/0 mA) = 0... 20 mA

Online- / offline mode (ONL/OFFL) = offline

Interface settings:

Emissivity (Emi) = 100%

Exposure time (t_{90}) = 0.08 s

Analog output (4/0 mA) = 0... 20 mA

Baud rate = 19200 Bd

Address = 00

Max./min. value storage = max.

Clear time of max./min. value storage = OFF

Ambient temperature compensation = auto

Wait time t_w = 02 Bit

5 Settings / Parameter Descriptions

5.1 Online- / offline mode (ONL/OFFL)

Offline (OFFL): If the settings directly at the pyrometer should be used (emissivity, exposure time and analog output) the pyrometer must be switched into offline mode (OFFL). In the offline mode these parameters cannot be adjusted via digital interface and PC, they can only be read! This prevents incorrect set-up or undesired changes via the interface. All additional available parameters always can be altered via serial interface.

Online (ONL): When switched to the online mode (ONL), only the serial interface can be used to set the values for the parameters - the instrument's switch settings are ignored. The device is initialized in "online" mode, i.e. it uses the last values set via serial interface!

5.2 Emissivity (EMI)

For a correct measurement it is necessary to adjust the emissivity. This emissivity is the relationship between the emission of a real object and the emission of a black body radiation source (this is an object which absorbs all incoming rays and has an emissivity of 100%) at the same temperature.

<u>Settings:</u>
100%
⋮
20%

Different materials have different emissivities ranging between 0% and 100% (settings at the pyrometer between 20 and 100%). Additionally, the emissivity is depending on the surface condition of the material, the spectral range of the pyrometer and the measuring temperature. The emissivity setting of the pyrometer has to be adjusted accordingly. Typical emissivity values of various common materials for the two spectral ranges of the instruments are listed below. The tolerance of the emissivity values for each material is mainly dependent on the surface conditions. Rough surfaces have higher emissivities.



Note: The minimum emissivity setting for the pyrometer is 20%!

Measuring object	EMI (@ 8 ... 14 μm)
"Black body furnace"	100%
Human skin	98%
Black dull varnish	95%
Carbon soot	95%
Wood	80 ... 92%
Paper	92 ... 95%
Asphalt	85%
Glass / quartz glass	72 ... 87%
Textile	75 ... 95%
Graphite	75 ... 92%
Cement	90%
Water	95%

Measuring object	EMI (@ 8 ... 14 μm)
Brickwork	85... 95%
Fire clay	
Rubber	
Porcelain	
Ceramics	
Varnish	
Plaster	
Oil paint	
Steel (oxidized)	
Steel (smooth)	10 ... 30%
Aluminum (smooth)	2 ... 15%
Aluminum (anodized)	90%

Measuring object	EMI (@ 5.14 μm)
Glass / quartz glass	97%

One way to determine an accurate emissivity value for a material is to make a comparison measurement as follows: If possible, coat a portion of the object with dull black paint or carbon soot. Paint and carbon soot have high emissivities (95%) and take on the same temperature as the object. Measure the temperature of the painted area with the emissivity control set to 95%. Then measure the temperature of an adjacent unpainted area of the object and adjust the emissivity until the pyrometer displays the same temperature.

Setting examples at the instrument:

Emi = 100%:



Emi = 85%:

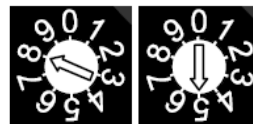

If the settings directly at the pyrometer should be used the pyrometer must be switched into offline mode (OFFL, see 5.1). To adjust the emissivity via software see description or online help of InfraWin software.



Note: If the emissivity is set to an incorrect value (below 20%) the instrument will automatically utilize an emissivity value of 100%. The setting 00 is interpreted as Emi = 100%.

5.3 Exposure time (t_{90})

The exposure time is the time interval when the measured temperature has to be present after an abrupt change so that the output value of the pyrometer reaches a given measurement value. The time taken is to reach 90% of the recorded temperature difference. Slower response time can be an advantage when trying to measure an object that has a rapidly fluctuating temperature.

To change the exposure time the corresponding DIP switch for 0.5 s, 1 s, 2 s or 5 s must be set in the ON position. A longer response time of 10 s can be set if the switch for 0.5 s and 5 s is set to the ON position at the same time, a longer response time of 30 s can be set if the switch for 1 s and 5 s is set at to the ON position the same time. In the "OFF" position (Software InfraWin: $t_{90} = \text{min}$), the device operates using its time constant (see technical data).

If the settings directly at the pyrometer should be used the pyrometer must be switched into offline mode (OFFL, see 5.1). To adjust the exposure time via software see description or online help of InfraWin software.

Setting examples at the instrument:

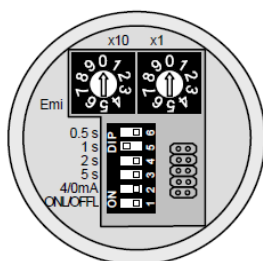

Example: $t_{90} = 1 \text{ s}$

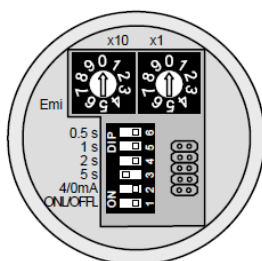

Example: $t_{90} = 5 \text{ s}$

5.4 Analog output 0/4 to 20 mA

When the DIP switch 2 is in the ON position, the analog output will be 4 - 20 mA, in the OFF position, the analog output will be 0 - 20 mA. The analog output has to be selected according to the signal input of the connected instrument (controller, PLC, etc.).

If the settings directly at the pyrometer should be used the pyrometer must be switched into offline mode (OFFL, see 5.1). To adjust the analog output via software see description or online help of InfraWin software.

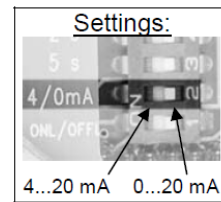

5.5 Maximum / minimum value storage

If the maximum value storage is switched on always the highest last temperature value will be displayed and stored. The minimum value storage saves the lowest measurement taken during a reading (e.g. practical when monitoring cooled goods such as frozen foods). The storage has to be cleared at regular intervals for exchanging by a new and actual value.

This feature is particularly useful when fluctuating object temperatures cause the display or the analog outputs to change too rapidly, or the pyrometer is not constantly viewing an object to be measured. In addition, it may also be beneficial to periodically delete and reset the stored maximum values.

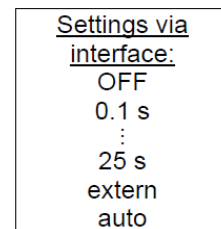

The following settings are possible:

- off: The max. value storage is switched off and only momentary values are measured.
- 0.01...25 s: If any clear time between 0.01 s and 25 s is set, the maximum value is estimated and held in double storage mode. After the entered time the storage will be deleted.
- extern: The external clearing can be activated and used within an own software (see section 9, **Data format UPP**) or via an external contact (for connection see **3.1.1 Pin assignment** for the connector on the back side of the pyrometer). In this case, the storage operates only in single storage, because only a single deletion mechanism is used.
- auto: The "auto" mode is used for discontinuous measuring tasks. For example, objects are transported on a conveyer belt and pass the measuring beam of the pyrometer only for a few seconds. Here the maximum value for each object must be indicated. In this mode the maximum value is stored until a new hot object appears in the measuring beam. The temperature which has to be recognized as "hot" is defined by the low limit of the adjusted sub range. The stored maximum value will be deleted when the temperature of the new hot object exceeds the low limit "from" of the sub range by 1% or at least 2 °C. If a lower limit is not entered, the maximum value storage will be deleted whenever the lower level of the full measuring range has been exceeded.

The minimum value function operates in the opposite manner. The minimum value stored will be deleted when the upper limit of the set range is below it by 1% (at least 2 °C). If an upper limit is not entered, the minimum value stored will be deleted whenever it drops below the upper level of the full measuring range.

Operation note: dependent on the settings the maximum value storage either works in single storage mode or in double storage mode:

Single storage: the single storage is used when you want to reset the stored value using an external impulse via one contact closure from an external relay (i.e. between two measured objects). The relay contact is connected directly to the pyrometer between pins J and K. This mode allows a new value to be established, after each impulse from the reset signal.

Double storage: when entering the reset intervals via push buttons or PC interface the double storage is automatically selected. This mode utilizes two memories in which the highest measured value is held and is deleted alternately in the time interval set (clear time). The other memory retains the maximum value throughout the next time interval. The disadvantages of fluctuations in the display with the clock frequency are thereby eliminated.



Note: The maximum value storage follows the function of adjustment of exposure time.

This results in:

- clear time \leq the adjusted response time is useless
- clear times must be at least 3 times longer than the response time
- only maxima with full maximum value can be recorded, which appear at least 3 times longer than the response time.

5.6 Subrange

You have the opportunity to choose a subrange (minimum 51 °C) within the basic measuring range of the pyrometer. This subrange corresponds to the complete analog output. The lower value (0 or 4 mA) describes the beginning of this measuring range, the upper value (20 mA) the end of the range.

Additionally, with the setting of a subrange it is possible to fulfill the requirements of the "auto" clear mode of the maximum value storage (see **5.5 Maximum / minimum value storage**).

5.7 Baud rate

The transmission rate of the serial interface in Baud (Bd) is dependent on the length of the cable. A standard cable length with RS232 for 19200 Bd is 7 m, with RS485 2 km. The baud rate is reduced by 50% if the transmission distance is doubled.

<u>Settings via interface:</u> 1.2 kBd ⋮ 19.2 kBd
--

5.8 Address

For the connecting of several pyrometers with RS485 with one serial interface it is necessary to give each instrument an individual address for communication. First it is necessary to connect each single instrument to give it an address. After that all instruments can be connected and addressed individually. If parameters may be changed simultaneously on all pyrometers, the global Address 98 can be used. This allows you to program all pyrometers at the same time, regardless of the addresses that have already been assigned. If the address of a pyrometer is unknown, it is possible to communicate with it using the global **Address 99** (connect only one pyrometer).

<u>Settings via interface:</u> 00 ⋮ 97

5.9 Ambient temperature compensation

Each object has an emissivity ϵ (maximum 100%). If the measured object is not transparent and has an emissivity of less than 1 (as in most cases), a portion of the resulting radiation will be reflected.

For bright, smooth surfaces, such as mirrors, the reflected radiation is more focused; on rough, harsh surfaces it is diffuse. The rate of diffuse reflection is, in this case $(1 - \epsilon)$.

If the measured object's temperature is the same as the ambient temperature (this is most often the case), you only need to set the emissivity on the pyrometer (when using the InfraWin program the off-set compensation for the ambient temperature must be in "auto").

If the object to be measured is in an oven, where the temperature is higher than the ambient temperature, a portion of the radiation, corresponding to the rate of diffuse reflection, will be "reflected" by the measured object to the pyrometer, resulting in an inaccurate reading (the reading will be too high due to the oven temperature).

In this case, it makes sense to activate the off-set compensation for the ambient temperature (in the parameter window of the InfraWin program: Compensating for the off-set of the ambient temperature switched to "man." (= manual) and then enter the ambient temperature value (in this case, the oven temperature) in the corresponding field. The program also makes a compensation calculation in order to display the correct temperature.

Be aware that the accuracy of such a correction is highly dependent on accuracy of the emissivity value that was set. The off-set compensation for the ambient temperature uses the rate of diffuse reflection when performing its calculation. If you alter the emissivity (ϵ), you are also altering the rate of diffuse reflection $(1 - \epsilon)$ and in turn, the displayed temperature. The following observation shows how a faulty emissivity reading in conjunction with the compensation for the ambient temperature affects results:

Entry of $\epsilon = 91\%$ instead of 92% indicates:

A relative change in emissivity of 1.1%.

Likewise, the assumed rate of reflection changes from 8% to 9%.

This results in a relative increase in reflection of 12.5%.

This change also impacts the displayed result, thereby causing an inaccurate compensation calculation.

For hot environments, this calculation will probably serve as a much more accurate assessment than the standard calculation, which assumes that the ambient temperature is the same as that of the object measured.

5.10 Wait time t_w

(only available via interface commands, see **9, Data format UPP**)

Using a pyrometer with RS485 it is possible that the connection is not fast enough to receive the pyrometer's answer to an instruction of the master. In this case a wait time can be set to slow down the data transfer (e.g.: $t_w = 02$ at a baud rate 9600 means a wait time of $2/9600$ sec).

<u>Settings:</u> 00 Bit ⋮ 99 Bit

5.11 Internal temperature of the pyrometer

The internal temperature of the pyrometer can be read via interface. It is a few degrees above the ambient temperature due to the warming generated by the pyrometer electronics.

5.12 Avoiding reading errors caused by faulty assembly

To avoid reading errors, please note the following points when mounting the pyrometer:

1. The diameter of the measuring object cannot be smaller than the pyrometer's spot size (see section **3.3, Optics**).
2. A source of radiation behind or around the measuring object can influence the result. If the object is transparent or partly transparent another material behind the object could transmit its radiation to the pyrometer as well. In this case the location of the pyrometer should be changed, or, if the background radiation remains constant it can be compensated for by changing the emissivity setting respectively.
3. Please take into account that radiation, from other hot materials around the measured object, can be reflected by these materials and influence the result. If the measured object has a low emissivity, the temperature measured will be mainly that from the reflected object - not from the intended measured object itself. To prevent ambient radiation from reaching the spot area, a mounting tube should be used. The mounting tube should be placed as near as possible to the measured object so that the tube's shadow blocks out all the ambient radiation from the side. Consider whether **5.9 Ambient temperature compensating** applies to the measurement application.

6 Software InfraWin

The operating and analyzing *InfraWin* software is included with delivery of the pyrometer. In addition to allowing you to make parameter adjustments via PC, the *InfraWin* software also provides temperature indication, data logging, and measurement analysis features.

A software description can be found in the program's help menu. Click on the F1 button after loading *InfraWin* or click on the ? in the menu bar.

The latest version is available for free as download from the homepage www.lumasenseinc.com.

6.1 Connecting the pyrometer to a PC

The program *InfraWin* can operate up to two devices. Two devices using RS485 may be operated simultaneously by the same interface, if two different addresses have been properly entered.

6.2 Installation

To install the *InfraWin* software, select setup.exe from the *InfraWin*-CD or from the downloaded and unpacked zip file from the internet and then follow the installation instructions.

6.3 Program start

The first time you load *InfraWin*, you will be prompted to select a default language. The *InfraWin* software is available in German, English, Spanish, French, Portuguese, and Chinese. Once installed, click **Language/Languages** if you would like to select another language.

To ensure consistent document formatting, this page was intentionally left blank.

7 Maintenance

7.1 Safety



Attention during pyrometer services: Should the pyrometer be integrated in a running machine process the machine has to be switched off and secured against restart before servicing the pyrometer.

7.2 Service

The pyrometer does not have any parts which require regular service, only the lens must be kept clean. The lens can be cleaned with a soft cloth in combination with alcohol (do not use acid solutions or dilution).

Also, standard cloths for cleaning glasses or photo objectives can be used.

To ensure consistent document formatting, this page was intentionally left blank.

8 Troubleshooting

Before sending the pyrometer for repair, try to find the error and to solve the problem with the help of the following list.

Temperature indication too low

- Incorrect alignment of the pyrometer to the object.
⇒ New correct alignment to achieve the max. temperature signal (see **3.2.1**).
- Measuring object smaller than spot size.
⇒ Check measuring distance, smallest spot size is at nominal measuring distance (see **3.3**).
- Measuring object is not always in the measuring spot of the pyrometer
⇒ Use max. value storage (see **5.5**).
- Emissivity set too high.
⇒ Set lower correct emissivity slope corresponding to the material (see **5.2**).
- Lens contaminated
⇒ Clean lens carefully (see **7.2**)

Temperature indication too high

- Emissivity slope set too low.
⇒ Set lower correct emissivity slope corresponding to the material (see **5.2**).
- The measurement is influenced by reflections of hot machine parts.
⇒ Use mechanical construction to avoid the influence of the interfering radiation.

Measuring errors

- Indicated temperature is decreasing during the use of the pyrometer, contamination of the lens.
⇒ Clean lens. Recommendation: use of air purge (see **2.6, 7.2**).
- Indicated temperature is decreasing during the use of the pyrometer, although the air purge unit is used. Probably compressed air is not clean or air failed.
⇒ Clean the lens and use clean, dry and oil free compressed air.
- Air contamination in the sighting path between pyrometer and object
⇒ Change position of the pyrometer with a clean sighting path (if necessary use a ratio pyrometer).
- HF-interferences.
⇒ Correct the connection of the cable shield.
- Instrument overheated
⇒ Use cooling jacket with air or water cooling (see **2.6**).
- Temperature Indication is fluctuating, probably caused by changing emissivity
⇒ Wrong pyrometer type, use of ratio pyrometer recommended

Laser targeting light

- Laser targeting light fails
⇒ Instruments temperature above 50 °C. Use cooling jacket (see **3.2.1, 2.6**)

To ensure consistent document formatting, this page was intentionally left blank.

9 Data format UPP

Via interface and a suitable communication software or via "Test" function of the InfraWin software commands can be exchanged directly with the pyrometer.



Note: The ONL/OFFL switch must be in the ONL position before adjusting the following parameters via the software (see **5.1**).

The data exchange occurs in ASCII format with the following transmission parameters:

The data format is: 8 data bits, 1 stop bit, even parity (8,1,e)

The device responds to the entry of a command with: output (e.g. the measuring value) + CR (Carriage Return, ASCII 13), to pure entry commands with "ok" + CR.

Every command starts with the 2-digit device address AA (e.g. "00").

This is followed by 2 small command letters (e.g. "em" for emissivity), followed, if necessary for that command, by the ASCII parameter "X" and finished with CR. If this parameter "X" is omitted, then the device answers with the current set parameter.

A „?“ after the small command letters answers with the respective settings (only at setting commands, not at enquiry commands).

Example: Entry: "00em" + <CR>

The emissivity setting (ϵ) of the device with the address 00 is returned
Answer: "0970" + <CR> means Emissivity = 97.0%

Description	Command	Parameters
Reading measuring value:	AAms	Output: YYYYY 5-digit decimal, in $1/10$ °C or °F 88880 = temp. overflow 02563 = 256.3 °C or °F -0170 = -17.0 °C or °F
Emissivity:	AAemXX AAemXXXX	XX = 20 ... 99%, 00 = 100% (decimal) XXXX = 0200 ... 1000 in %
Exposure time t_{90} :	AAezX	X = 0 ... 6 (decimal) 0 = intrinsic time constant of the device 1 = 0.5 s 3 = 2 s 5 = 10 s 2 = 1 s 4 = 5 s 6 = 30 s
Analog output ¹⁾ :	AAasX	X = 0;1 0 = 0 - 20 mA 1 = 4 - 20 mA
Clear time of maximum / minimum value storage:	AAlzX	X = 0 to 8 (decimal) 0 = maximum/minimum value storage off 1 = 0.10 s 5 = 5.00 s 2 = 0.25 s 6 = 25.00 s 3 = 0.50 s 7 = externally deleted 4 = 1.00 s 8 = automatically cleared
External clearing:	AAlx	Simulation of an external clearing contact

Changing °C / °F ¹):	AAfhX	X = 0;1 (decimal) 0 = Output Celsius 1 = Output Fahrenheit
Reading basic temperature range:	AAmb	Output: YYYYZZZZ 8-digit hex in °C or °F YYYY = beginning of temperature range ZZZZ = end of temperature range
Reading sub range:	AAme	As with mb
Repeatedly reading measuring values:	AAmsXXX	XXX = 000 to 999 XXX = No. of measuring values
Laser targeting light:	AAlaX	X = 0;1 (decimal) 0 = switch off pilot light 1 = switch on pilot light
Error status:	AAfs	Output 1 Byte hex Bit 0 = 1: EEPROM error Bit 1 = 1: Watch dog Reset Bit 2 = 1: Under voltage reset
Reading parameter:	AApa	Output 11-digit decimal: Digit 1 and 2 (20 to 99 or 00): emissivity Digit 3 (0 to 6): t90 (exposure time) Digit 4 (0 to 8): tCL (storage delete mode) Digit 5 (0 to 1): analog output Digits 6 and 7 (00 to 98): temperature Digits 8 and 9 (00 to 31): address Digit 10 (0 to 4): baud rate Digit 11 always 0
Device address ¹):	AAgaXX	XX: Device address decimal 00 to 31 variable device addresses
Baud rate:	AAbrX	X = 0 to 4 0: 1200 Bd 2: 4800 Bd 4: 19200 Bd 1: 2400 Bd 3: 9600 Bd
Internal pyrometer temperature:	AAgt	Output: XX (dec. 00 to 98, in °C)
Max. internal pyrometer temperature:	AAtm	Output: XX (dec. 00 to 98, in °C)
Reset ¹):	AAre	Reset device
Command delay:	AAtwXX	XX = 00 to 20 relative delay value
Reading ambient temperature:	AAut	Output: stored value, 4-digit hex e.g. 0258 corresponds to 600 degrees
Entering ambient temperature:	AAutXXXX	XXXX = value of ambient temperature, 4-digit, hex XXXX e.g. FFEC corresponds to -20 degrees - 99dez = FF9Dhex means: automatic, no manual compensation
Marginal values for ambient temperature:	AAut?	Output: marginal values for the entry, 2 x 4-digit, hex e.g. FF9D0384 corresponds to -99 to 900 degrees

Reading maximum / minimum values:	AAmi	Output: 0 or 1 0 = maximum value, 1 = minimum value
Setting maximum / minimum values:	AAmiX	X = desired setting 0 = maximum value, 1 = minimum value
Reading marginal values:	AAmi?	Output: marginal value for entry, always 01
Serial number:	AAsn	Output: XXXXX (5-digit decimal)
Device model / software version:	AAve	Output: XXYYZZ (6-digit decimal) XX = 70 YY = month of the software version ZZ = year of the software version



Note: The letter "l" means the lower-case letter of "L".

¹⁾After entering these commands the device carries out an automatic reset. The device needs approx. 150 ms before it is ready to use and work with the changed settings.

Additional instruction for the RS485 interface:

Requirements to the master system during half-duplex operation:

1. After an inquiry, the bus should be switched into a transmission time of 3 bits (some older interfaces are not fast enough for this).
2. The pyrometer's response will follow after 5 ms at latest.
3. If there is no response, there is a parity or syntax error and the inquiry has to be repeated.

To ensure consistent document formatting, this page was intentionally left blank.

10 Reference numbers

10.1 Reference numbers instrument

	Optics	Temperature Range	Interface	
			RS232	RS485
IN 5 plus	100	-32 ... 900 °C (MB 9)	3 869 400	3 869 410
	300		3 869 420	3 869 430
	800		3 869 440	3 869 450
IN 5-H plus	100	-32 ... 900 °C (MB 9)	3 871 200	3 871 210
	300		3 871 220	3 871 230
	800		3 871 240	3 871 250
IN 5-L plus	100	0 ... 900 °C (MB 9)	3 871 600	3 871 610
	300		3 871 620	3 871 630
	800		3 871 640	3 871 650

Scope of delivery: Instrument with selected optic, works certificate, PC measurement and evaluation software InfraWin.

Ordering details: A connection cable is not included with the instrument and has to be ordered separately.

10.2 Reference numbers accessories

3 820 ...

Connection cables (straight plug):

5 m	10 m	15 m	20 m	25 m	30 m
... 330	... 500	... 510	... 810	... 820	... 520

3 820 320

Connection cable 5 m (angled connector, additional laser targeting light push button)

3 820 740

Connection cable 5 m, (straight connector, temperature resistant up to 200 °C)

3 852 290

Power supply NG DC (100 ... 240 V AC ⇒ 24 V DC, 1 A)

3 852 540

Power supply NG 0D (85 ... 265 V AC ⇒ 24 V DC, 600 mA)

3 852 440

Protocol converter RS485/RS232 (switchable) ⇔ Profibus-DP for 1 instrument

3 852 460

Protocol converter RS485 ⇔ Profibus-DP for 32 instruments

3 852 620

Protocol converter RS485/RS232 ⇔ Profinet (1 instrument)

3 852 630

Protocol converter RS485 ⇔ Profinet (32 instruments)

3 852 430

Converter I-7520; RS485 ⇔ RS232 (half duplex)

3 890 650

DA 4000: LED digital display, 2 limit switches, 230 V AC

3 891 220

DA 4000: LED digital display, 2 limit switches, 115 V AC

3 890 560

DA 6000-N: LED digital display with digital input RS232 and possibility for pyrometer parameter settings

3 890 570

DA 6000-N with RS485

3 890 520	DA 6000: LED digital display, digital and analog input, 2 limit switches, maximum value storage, analog output, RS232
3 890 530	DA 6000 with RS485
3 826 500	HT 6000: portable battery driven indicator and instrument for pyrometer parameter settings; RS232 and RS485 interface
3 826 510	PI 6000: programmable PID controller
3 843 500	SCA 5, Scanner for Series 5 mit CaF2 window; 24 V AC/DC
3 834 210	Adjustable mounting support
3 835 160	Air purge unit
3 835 440	Air purge unit, stainless steel
3 837 230	Water cooling jacket (heavy design) with integrated air purge unit (metric mounting threads)
5 837 230	Water cooling jacket (heavy design) with integrated air purge unit (UNC mounting threads)
3 837 350	Heavy water cooling jacket with protection window (with metric mounting threads)
3 837 370	Water cooling jacket (lightweight design) with integrated air purge unit (metric mounting threads)
5 837 370	Water cooling jacket (lightweight design) with integrated air purge unit (UNC mounting threads)
3 837 400	Lightweight water cooling jacket with protection window (with metric mounting threads)
3 846 100	Mounting tube
3 846 120	Flange tube
3 837 540	Cooling plate for series 5 and 6, with air purge
3 846 630	Vacuum flange KF16 with protection window
3 846 660	Spare protection window, Ø 25 x 3 with Viton-O-ring

Flange System:

3 846 260	Instrument's support
3 846 610	Support with ZnSe window (for IN 5 plus, IN 5-H plus, IN 5-L plus)
3 846 240	Tube support with air purge nozzle
3 846 750	Window slide, without window

Flange system: the flange system is a modular mounting system to fix the pyrometer on furnaces, vacuum chambers, etc. It can consist of e.g. mounting support, tube support with air purge and flange and an open or closed ceramic sighting tube. The mounting support can be equipped with a quartz window for vacuum applications.

Index

A

Accessories 13
Appropriate use 9

C

Connection cable 9
Controls and Connections 15

D

Disposal 8

E

Electrical Installation 15
Emissivity 23

F

Factory settings 22

G

General 5

I

Installation, electrical 15

L

Language 29
Legend 5
Liability 6

M

Maintenance 31

O

Optical head 18

P

Packaging 8
Parameter descriptions 23

R

Reference numbers 39
Repair 7
Response time / exposure time 24

S

Scope of delivery 9
Service Request 7
Settings 23
Software InfraWin 29
Storage 8
Support 7

T

Technical data 9
Transport, packaging, storage 8
Trouble shooting 33

U

Unpacking 7

W

Warranty 6